

DUAL SLURRY SWING CHECK VALVE



DUAL's Slurry Swing Check Valve operates on the discharge side of the pump as the flow through the pipeline starts or stops. The disc automatically rises and falls, opening and closing the valve. This occurs without noticeable shock or hammer, regardless of the line pressure or the speed of closure.

The Dual Slurry Swing Check Valve is particularly well suited for harsh highly abrasive flow control applications in liquid-solid and gas-solid pneumatic conveying services where long valve life and low maintenance are desired. The disc and seat are replaceable.

FEATURES

- Disc self-adjusts to flow.
- Long operating life due to the disc out of flow.
- Seals in one direction.
- Seals in zero back pressure.
- Virtually no pressure drop.
- Eliminates pipe hammer.
- Long seat life due to seat out of process flow.
- Flush ports.
- Drip-tight shut off.
- Full bore design with low friction loss and high flow capacity.
- Virtually maintenance free due to the simple design.
- Replaceable disc (single wearing part).
- Various lining options.
- Custom bodies for special applications.
- Replaceable disc and seat sleeve.

PRODUCT SPECIFICATION

BODY: Fabricated Carbon Steel.

REPLACEABLE SEAT SLEEVE: Rubber or Urethane.

DISC MATERIAL: Stainless Steel, Carbon Steel or Rubber coated.

BODY LINING: Gum Black, Red Rubber, EPDM, Butyl, Chlorobutyl, Neoprene, Ceramic, Polyurethane, Viton or Hypalon.

PRESSURE RATING: 16, 25, 40, 60 and 100 Bar.

SIZE RANGE: 50mm - 600mm.

DRILLING PATTERNS: Drilled to SABS, ANSI BS or DIN.

TEMPERATURE: -50°C to 180°C.

300#/25 BAR SLURRY APPLICATION



INSTALLATION

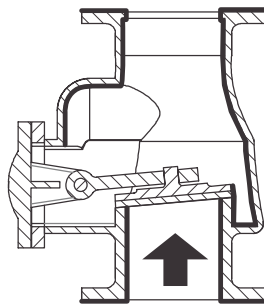

VERTICAL
INSTALLATION

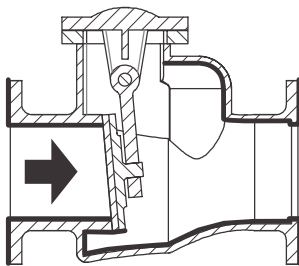

HORIZONTAL
INSTALLATION

DIMENSIONS AND SPECIFICATIONS

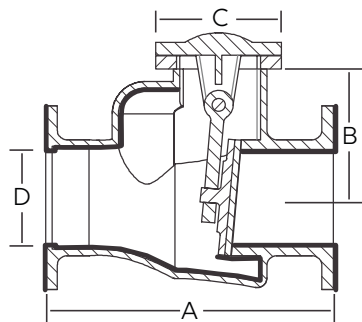

SIZE (mm)	F/F A	B	C	D	WEIGHT (kg)
50	230	135	181	50	20
80	305	176	229	80	40
100	355	196	267	100	50
150	445	246	333	150	100
200	535	310	413	200	150
250	635	366	502	250	250
300	760	402	584	300	350
350	865	485	610	350	590
400	865	560	673	400	750
450	Larger sizes available on request.				
500					
600					

Dimensions and weights are for guidance only - detailed dimension drawings available on request. All dimensions are in millimeters, unless stated.

APPLICATIONS

- Mining and mineral processing.
- Power generation.
- Sand and gravel.
- Chemical and soda ash.
- Pulp and paper.
- Environmental and effluent.
- Water and wastewater.

VALVE HEAD LOSS VALUES

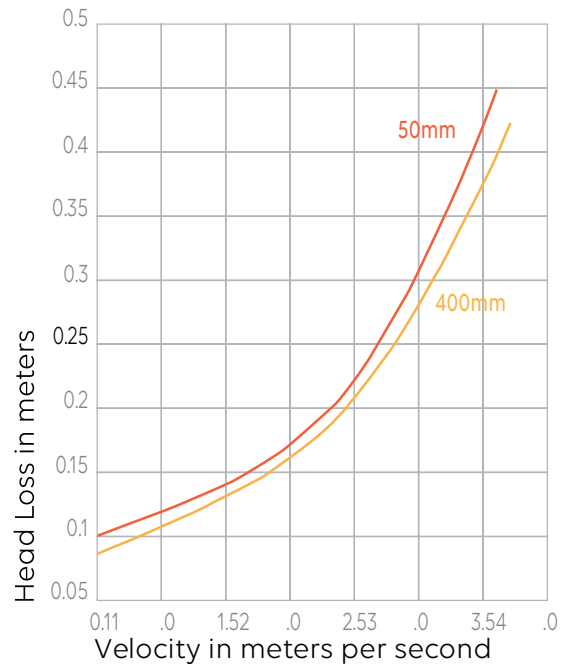

	PART	DESCRIPTION
1	Body/Cover	Fabrication
2	Check disc	Stainless Steel, Rubber coated
3	Hinge	Stainless Steel, Rubber coated
4	Hinge pin	304 Stainless Steel
5	Bolts and nuts	Cadmium plated steel
6	Seat sleeve	Rubber and Urethane
7	Body gasket	'O' Ring
8	Paint	Epoxy
9	Body lining	Rubber, Urethane or Ceramic

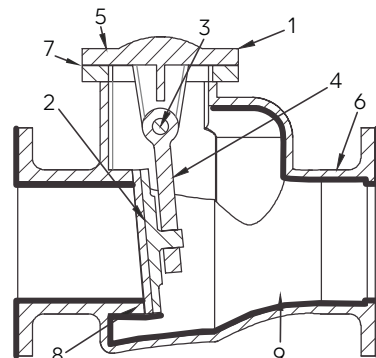

CORPORATE HEADQUARTERS:
166 ROTTERDAM ROAD
(CNR ROTTERDAM ROAD & ANTWERP STREET)
APEX, BENONI, GAUTENG, SOUTH AFRICA

PO BOX 12520, BENORYN 1504
TEL: +27 11 422 4326/7
FAX: +27 11 421 7842
EMAIL: SALES@DUALVALVES.COM

