



Taylor Valve Technology

5602

Air/Gas Regulator

The **5602** is spring-operated regulator used to supply air or gas to pilots, positioners or to pneumatic controls.

FEATURES:

- Inlet relief
- Dual outlet
- Built-in micron filter

SPECIFICATIONS:

Connection: 1/4" NPT

Temperature Range: -20°F to 180°F (-29°C to 82°C)

Inlet Pressure Rating: 250psi

Outlet Pressure Range:

5602-1 (0-30psi) **5602-2** (0-60psi) **5602-3** (0-120psi)

Body and Housing Material: Die Cast Aluminum

Capacities in SCFH OF 0.6 SG Natural Gas

Inlet Pressure (psi)	Outlet Pressure Setting (Spring Range)		
	25psi (0-30)	40psi (0-60)	80psi (0-120)
50	510	190	---
75	710	640	---
100	960	640	510
150	1290	900	840
250	1800	1900	1300

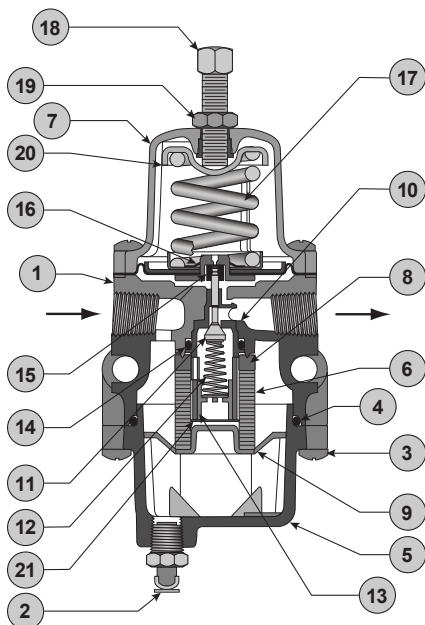
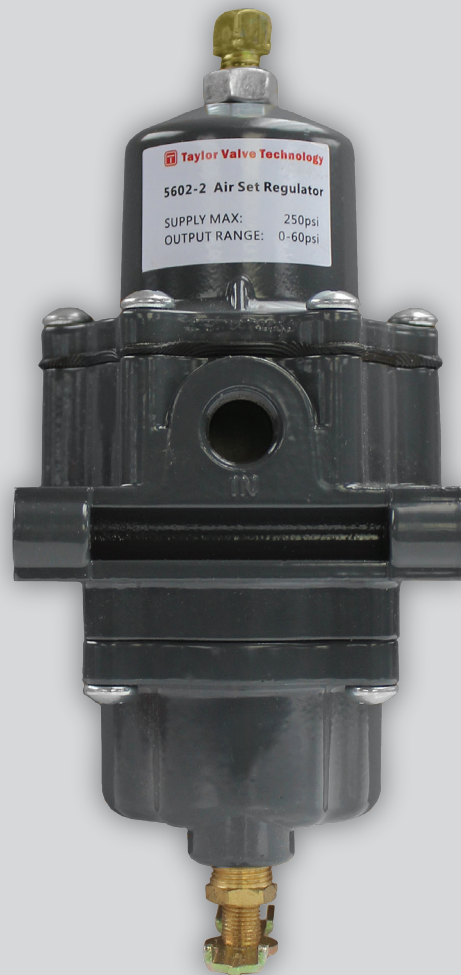

Parts List, Filtered Unit

Item	Description	Qty.
1	BODY	1
2	DRAIN VALVE	1
3	SCREW	10
4	O-RING	1
5	DRIPWELL	1
6	FILTER ELEMENT	1
7	SPRING CASE	1
8	FILTER GASKET	1
9	FILTER RETAINER	1
10	VALVE CARTRIDGE	1
11	VALVE PLUG	1
12	VALVE SPRING	1
13	VALVE RETAINER	1
14	O-RING	1
15	SOFT SEAT	1
16	DIAPHRAGM ASSY.	1
17	SPRING, 0-35#	1
17	SPRING, 0-60#	1
17	SPRING, 0-120#	1
18	ADJUSTING SCREW	1
19	LOCK NUT	1
20	UPPER SPRING SEAT	1
21	WASHER	1
22*	WASHER	2
23*	PIPE PLUG	1

* Not Shown

NOTE: Taylor Valve reserves the right to change product designs and specifications without notice.

Taylor Valve Technology

8300 S.W. 8th Street

Oklahoma City, Oklahoma 73128

TEL 405.787.0145

FAX 800.805.3401

WEB taylorvalve.com

INFO info@taylorvalve.com